

Programmable Controller

MELSEC iQ-R
series

MELSEC iQ-R AnyWireASLINK Master Module User's Manual (Startup)

-RJ51AW12AL

Powered by

Anywire

This product was jointly developed and manufactured by Mitsubishi and Anywire Corporation.

*Note that the warranty on this product differs from that on other programmable controller products.
(Refer to "WARRANTY" in this manual.)

AnyWireASLINK

COPYRIGHT

This document is protected by the law of copyright, whereby all rights established therein remain with the company Mitsubishi Electric Corporation. Reproduction of this document or parts of this document is only permissible within the limits of the legal determination of Copyright Law. Alteration or abridgement of the document is not permitted without the explicit written approval of the company Mitsubishi Electric Corporation.

PRECAUTIONS REGARDING WARRANTY AND SPECIFICATIONS

The RJ51AW12AL was jointly developed and manufactured by Mitsubishi and Anywire Corporation. Note that there are differences in warranty.

- Warranty

Item	RJ51AW12AL	Other programmable controller products (e.g. MELSEC iQ-R series)
Repair term after discontinuation of production	1 year	7 years

- Application of the EMC Directive

Item	RJ51AW12AL	Other programmable controller products (e.g. MELSEC iQ-R series)
Applicable EMC standard	EN61131-2	EN61131-2

- Application of the UL/cUL standards

Item	RJ51AW12AL	Other programmable controller products (e.g. MELSEC iQ-R series)
Applicable UL standard/cUL standard	UL508 CSA22.2	UL508 CSA22.2

SAFETY PRECAUTIONS

(Read these precautions before using this product.)

Before using this product, please read this manual and the relevant manuals carefully and pay full attention to safety to handle the product correctly.

The precautions given in this manual are concerned with this product only. For the safety precautions of the programmable controller system, refer to the MELSEC iQ-R Module Configuration Manual.

In this manual, the safety precautions are classified into two levels: "⚠ WARNING" and "⚠ CAUTION".



WARNING

Indicates that incorrect handling may cause hazardous conditions, resulting in death or severe injury.



CAUTION

Indicates that incorrect handling may cause hazardous conditions, resulting in minor or moderate injury or property damage.

Under some circumstances, failure to observe the precautions given under "⚠ CAUTION" may lead to serious consequences.

Observe the precautions of both levels because they are important for personal and system safety.

Make sure that the end users read this manual and then keep the manual in a safe place for future reference.

[Design Precautions]

WARNING

- Configure safety circuits external to the programmable controller to ensure that the entire system operates safely even when a fault occurs in the external power supply or the programmable controller. Failure to do so may result in an accident due to an incorrect output or malfunction.
 - (1) Emergency stop circuits, protection circuits, and protective interlock circuits for conflicting operations (such as forward/reverse rotations or upper/lower limit positioning) must be configured external to the programmable controller.
 - (2) When the programmable controller detects an abnormal condition, it stops the operation and all outputs are:
 - Turned off if the overcurrent or overvoltage protection of the power supply module is activated.
 - Held or turned off according to the parameter setting if the self-diagnostic function of the CPU module detects an error such as a watchdog timer error.
 - (3) All outputs may be turned on if an error occurs in a part, such as an I/O control part, where the CPU module cannot detect any error. To ensure safety operation in such a case, provide a safety mechanism or a fail-safe circuit external to the programmable controller. For a fail-safe circuit example, refer to "General Safety Requirements" in the MELSEC iQ-R Module Configuration Manual.
 - (4) Outputs may remain on or off due to a failure of a component such as a relay and transistor in an output circuit. Configure an external circuit for monitoring output signals that could cause a serious accident.
 - In an output circuit, when a load current exceeding the rated current or an overcurrent caused by a load short-circuit flows for a long time, it may cause smoke and fire. To prevent this, configure an external safety circuit, such as a fuse.
 - For the operating status of each station after a communication failure, refer to manuals relevant to the network. Incorrect output or malfunction due to a communication failure may result in an accident.
 - When connecting an external device with a CPU module or intelligent function module to modify data of a running programmable controller, configure an interlock circuit in the program to ensure that the entire system will always operate safely. For other forms of control (such as program modification, parameter change, forced output, or operating status change) of a running programmable controller, read the relevant manuals carefully and ensure that the operation is safe before proceeding. Improper operation may damage machines or cause accidents.
-

[Design Precautions]

WARNING

- Especially, when a remote programmable controller is controlled by an external device, immediate action cannot be taken if a problem occurs in the programmable controller due to a communication failure. To prevent this, configure an interlock circuit in the program, and determine corrective actions to be taken between the external device and CPU module in case of a communication failure.
 - Do not write any data to the "system area" and "write-protect area" of the buffer memory in the module. Also, do not use any "use prohibited" signals as an output signal from the CPU module to each module. Doing so may cause malfunction of the programmable controller system. For the "system area", "write-protect area", and the "use prohibited" signals, refer to the user's manual for the module used.
 - If a communication cable is disconnected, the network may be unstable, resulting in a communication failure of multiple stations. Configure an interlock circuit in the program to ensure that the entire system will always operate safely even if communications fail. Failure to do so may result in an accident due to an incorrect output or malfunction.
 - To maintain the safety of the programmable controller system against unauthorized access from external devices via the network, take appropriate measures. To maintain the safety against unauthorized access via the Internet, take measures such as installing a firewall.
 - An AnyWireASLINK system has no control function for ensuring safety.
-

[Design Precautions]

CAUTION

- Do not install the control lines or communication cables together with the main circuit lines or power cables. Keep a distance of 100mm or more between them. Failure to do so may result in malfunction due to noise.
 - During control of an inductive load such as a lamp, heater, or solenoid valve, a large current (approximately ten times greater than normal) may flow when the output is turned from off to on. Therefore, use a module that has a sufficient current rating.
 - After the CPU module is powered on or is reset, the time taken to enter the RUN status varies depending on the system configuration, parameter settings, and/or program size. Design circuits so that the entire system will always operate safely, regardless of the time.
 - Do not power off the programmable controller or reset the CPU module while the settings are being written.
Doing so will make the data in the flash ROM and SD memory card undefined. The values need to be set in the buffer memory and written to the flash ROM and SD memory card again. Doing so also may cause malfunction or failure of the module.
 - When changing the operating status of the CPU module from external devices (such as the remote RUN/STOP functions), select "Do Not OPEN in Program" for "Open Method Setting" of "Module Parameter". If "OPEN in Program" is selected, an execution of the remote STOP function causes the communication line to close. Consequently, the CPU module cannot reopen the line, and external devices cannot execute the remote RUN function.
-

[Installation Precautions]

WARNING

- Shut off the external power supply (all phases) used in the system before mounting or removing the module. Failure to do so may result in electric shock or cause the module to fail or malfunction.
-

[Installation Precautions]

CAUTION

- Use the programmable controller in an environment that meets the general specifications in the Safety Guidelines included with the base unit. Failure to do so may result in electric shock, fire, malfunction, or damage to or deterioration of the product.
 - To mount a module, place the concave part(s) located at the bottom onto the guide(s) of the base unit, and push in the module until the hook(s) located at the top snaps into place. Incorrect interconnection may cause malfunction, failure, or drop of the module.
 - To mount a module with no module fixing hook, place the concave part(s) located at the bottom onto the guide(s) of the base unit, push in the module, and fix it with screw(s). Incorrect interconnection may cause malfunction, failure, or drop of the module.
 - When using the programmable controller in an environment of frequent vibrations, fix the module with a screw.
 - Tighten the screws within the specified torque range. Undertightening can cause drop of the screw, short circuit, or malfunction. Overtightening can damage the screw and/or module, resulting in drop, short circuit, or malfunction.
 - When using an extension cable, connect it to the extension cable connector of the base unit securely. Check the connection for looseness. Poor contact may cause malfunction.
 - When using an SD memory card, fully insert it into the SD memory card slot. Check that it is inserted completely. Poor contact may cause malfunction.
 - Securely insert an extended SRAM cassette or a battery-less option cassette into the cassette connector of the CPU module. After insertion, close the cassette cover and check that the cassette is inserted completely. Poor contact may cause malfunction.
 - Do not directly touch any conductive parts and electronic components of the module, SD memory card, extended SRAM cassette, battery-less option cassette, or connector. Doing so can cause malfunction or failure of the module.
-

[Wiring Precautions]

WARNING

- Shut off the external power supply (all phases) used in the system before installation and wiring. Failure to do so may result in electric shock or cause the module to fail or malfunction.
 - After installation and wiring, attach a blank cover module (RG60) to each empty slot and an included extension connector protective cover to the unused extension cable connector before powering on the system for operation. Failure to do so may result in electric shock.
-

[Wiring Precautions]

CAUTION

- Individually ground the FG and LG terminals of the programmable controller with a ground resistance of 100 ohms or less. Failure to do so may result in electric shock or malfunction.
 - Use applicable solderless terminals and tighten them within the specified torque range. If any spade solderless terminal is used, it may be disconnected when the terminal screw comes loose, resulting in failure.
 - Check the rated voltage and signal layout before wiring to the module, and connect the cables correctly. Connecting a power supply with a different voltage rating or incorrect wiring may cause fire or failure.
 - Connectors for external devices must be crimped or pressed with the tool specified by the manufacturer, or must be correctly soldered. Incomplete connections may cause short circuit, fire, or malfunction.
 - Securely connect the connector to the module. Poor contact may cause malfunction.
 - Do not install the control lines or communication cables together with the main circuit lines or power cables. Keep a distance of 100mm or more between them. Failure to do so may result in malfunction due to noise.
 - Place the cables in a duct or clamp them. If not, dangling cable may swing or inadvertently be pulled, resulting in damage to the module or cables or malfunction due to poor contact. Do not clamp the extension cables with the jacket stripped. Doing so may change the characteristics of the cables, resulting in malfunction.
 - Check the interface type and correctly connect the cable. Incorrect wiring (connecting the cable to an incorrect interface) may cause failure of the module and external device.
 - Tighten the terminal screws or connector screws within the specified torque range. Undertightening can cause drop of the screw, short circuit, fire, or malfunction. Overtightening can damage the screw and/or module, resulting in drop, short circuit, fire, or malfunction.
 - When disconnecting the cable from the module, do not pull the cable by the cable part. For the cable with connector, hold the connector part of the cable. For the cable connected to the terminal block, loosen the terminal screw. Pulling the cable connected to the module may result in malfunction or damage to the module or cable.
-

[Wiring Precautions]

CAUTION

- Prevent foreign matter such as dust or wire chips from entering the module. Such foreign matter can cause a fire, failure, or malfunction.
 - A protective film is attached to the top of the module to prevent foreign matter, such as wire chips, from entering the module during wiring. Do not remove the film during wiring. Remove it for heat dissipation before system operation.
 - Programmable controllers must be installed in control panels. Connect the main power supply to the power supply module in the control panel through a relay terminal block. Wiring and replacement of a power supply module must be performed by qualified maintenance personnel with knowledge of protection against electric shock. For wiring, refer to the MELSEC iQ-R Module Configuration Manual.
 - For Ethernet cables to be used in the system, select the ones that meet the specifications in the user's manual for the module used. If not, normal data transmission is not guaranteed.
 - Do not apply the 24VDC power before wiring the entire AnyWireASLINK system. If the power is applied before wiring, normal data transmission is not guaranteed.
 - Connect a 24VDC external power supply to the device(s) in an AnyWireASLINK system.
-

[Startup and Maintenance Precautions]

WARNING

- Do not touch any terminal while power is on. Doing so will cause electric shock or malfunction.
 - Correctly connect the battery connector. Do not charge, disassemble, heat, short-circuit, solder, or throw the battery into the fire. Also, do not expose it to liquid or strong shock. Doing so will cause the battery to produce heat, explode, ignite, or leak, resulting in injury and fire.
 - Shut off the external power supply (all phases) used in the system before cleaning the module or retightening the terminal screws, connector screws, or module fixing screws. Failure to do so may result in electric shock.
-

[Startup and Maintenance Precautions]

CAUTION

- When connecting an external device with a CPU module or intelligent function module to modify data of a running programmable controller, configure an interlock circuit in the program to ensure that the entire system will always operate safely. For other forms of control (such as program modification, parameter change, forced output, or operating status change) of a running programmable controller, read the relevant manuals carefully and ensure that the operation is safe before proceeding. Improper operation may damage machines or cause accidents.
 - Especially, when a remote programmable controller is controlled by an external device, immediate action cannot be taken if a problem occurs in the programmable controller due to a communication failure. To prevent this, configure an interlock circuit in the program, and determine corrective actions to be taken between the external device and CPU module in case of a communication failure.
 - Do not disassemble or modify the modules. Doing so may cause failure, malfunction, injury, or a fire.
 - Use any radio communication device such as a cellular phone or PHS (Personal Handy-phone System) more than 25cm away in all directions from the programmable controller. Failure to do so may cause malfunction.
 - Shut off the external power supply (all phases) used in the system before mounting or removing the module. Failure to do so may cause the module to fail or malfunction.
 - Tighten the screws within the specified torque range. Undertightening can cause drop of the component or wire, short circuit, or malfunction. Overtightening can damage the screw and/or module, resulting in drop, short circuit, or malfunction.
 - After the first use of the product, do not perform each of the following operations more than 50 times (IEC 61131-2/JIS B 3502 compliant).
Exceeding the limit may cause malfunction.
 - Mounting/removing the module to/from the base unit
 - Inserting/removing the extended SRAM cassette or battery-less option cassette to/from the CPU module
 - Mounting/removing the terminal block to/from the module
 - After the first use of the product, do not insert/remove the SD memory card to/from the CPU module more than 500 times. Exceeding the limit may cause malfunction.
 - Do not touch the metal terminals on the back side of the SD memory card. Doing so may cause malfunction or failure of the module.
 - Do not touch the integrated circuits on the circuit board of an extended SRAM cassette or a battery-less option cassette. Doing so may cause malfunction or failure of the module.
 - Do not drop or apply shock to the battery to be installed in the module. Doing so may damage the battery, causing the battery fluid to leak inside the battery. If the battery is dropped or any shock is applied to it, dispose of it without using.
 - Startup and maintenance of a control panel must be performed by qualified maintenance personnel with knowledge of protection against electric shock. Lock the control panel so that only qualified maintenance personnel can operate it.
 - Before handling the module, touch a conducting object such as a grounded metal to discharge the static electricity from the human body. Failure to do so may cause the module to fail or malfunction.
-

[Operating Precautions]

CAUTION

- When changing data and operating status, and modifying program of the running programmable controller from an external device such as a personal computer connected to an intelligent function module, read relevant manuals carefully and ensure the safety before operation. Incorrect change or modification may cause system malfunction, damage to the machines, or accidents.
 - Do not power off the programmable controller or reset the CPU module while the setting values in the buffer memory are being written to the flash ROM in the module. Doing so will make the data in the flash ROM and SD memory card undefined. The values need to be set in the buffer memory and written to the flash ROM and SD memory card again. Doing so can cause malfunction or failure of the module.
-

[Disposal Precautions]

CAUTION

- When disposing of this product, treat it as industrial waste.
 - When disposing of batteries, separate them from other wastes according to the local regulations. For details on battery regulations in EU member states, refer to the MELSEC iQ-R Module Configuration Manual.
-

[Transportation Precautions]

CAUTION

- When transporting lithium batteries, follow the transportation regulations. For details on the regulated models, refer to the MELSEC iQ-R Module Configuration Manual.
 - The halogens (such as fluorine, chlorine, bromine, and iodine), which are contained in a fumigant used for disinfection and pest control of wood packaging materials, may cause failure of the product. Prevent the entry of fumigant residues into the product or consider other methods (such as heat treatment) instead of fumigation. The disinfection and pest control measures must be applied to unprocessed raw wood.
-

CONDITIONS OF USE FOR THE PRODUCT

- (1) Mitsubishi programmable controller ("the PRODUCT") shall be used in conditions;
- i) where any problem, fault or failure occurring in the PRODUCT, if any, shall not lead to any major or serious accident; and
 - ii) where the backup and fail-safe function are systematically or automatically provided outside of the PRODUCT for the case of any problem, fault or failure occurring in the PRODUCT.
- (2) The PRODUCT has been designed and manufactured for the purpose of being used in general industries. MITSUBISHI SHALL HAVE NO RESPONSIBILITY OR LIABILITY (INCLUDING, BUT NOT LIMITED TO ANY AND ALL RESPONSIBILITY OR LIABILITY BASED ON CONTRACT, WARRANTY, TORT, PRODUCT LIABILITY) FOR ANY INJURY OR DEATH TO PERSONS OR LOSS OR DAMAGE TO PROPERTY CAUSED BY the PRODUCT THAT ARE OPERATED OR USED IN APPLICATION NOT INTENDED OR EXCLUDED BY INSTRUCTIONS, PRECAUTIONS, OR WARNING CONTAINED IN MITSUBISHI'S USER, INSTRUCTION AND/OR SAFETY MANUALS, TECHNICAL BULLETINS AND GUIDELINES FOR the PRODUCT.

("Prohibited Application")

Prohibited Applications include, but not limited to, the use of the PRODUCT in;

- Nuclear Power Plants and any other power plants operated by Power companies, and/or any other cases in which the public could be affected if any problem or fault occurs in the PRODUCT.
- Railway companies or Public service purposes, and/or any other cases in which establishment of a special quality assurance system is required by the Purchaser or End User.
- Aircraft or Aerospace, Medical applications, Train equipment, transport equipment such as Elevator and Escalator, Incineration and Fuel devices, Vehicles, Manned transportation, Equipment for Recreation and Amusement, and Safety devices, handling of Nuclear or Hazardous Materials or Chemicals, Mining and Drilling, and/or other applications where there is a significant risk of injury to the public or property.

Notwithstanding the above restrictions, Mitsubishi may in its sole discretion, authorize use of the PRODUCT in one or more of the Prohibited Applications, provided that the usage of the PRODUCT is limited only for the specific applications agreed to by Mitsubishi and provided further that no special quality assurance or fail-safe, redundant or other safety features which exceed the general specifications of the PRODUCTS are required. For details, please contact the Mitsubishi representative in your region.

INTRODUCTION

Thank you for purchasing the Mitsubishi Electric MELSEC iQ-R series programmable controllers.

This manual describes the procedures, system configuration, and wiring of the relevant product listed below.

Before using this product, please read this manual and the relevant manuals carefully and develop familiarity with the functions and performance of the MELSEC iQ-R series programmable controller to handle the product correctly.

When applying the program examples provided in this manual to an actual system, ensure the applicability and confirm that it will not cause system control problems.

Please make sure that the end users read this manual.

This module was jointly developed by Mitsubishi and Anywire Corporation. The module allows the AnyWireASLINK[®] system to be connected to a MELSEC iQ-R series programmable controller system.

Relevant product

RJ51AW12AL

COMPLIANCE WITH EMC AND LOW VOLTAGE DIRECTIVES

Method of ensuring compliance

To ensure that Mitsubishi programmable controllers maintain EMC and Low Voltage Directives when incorporated into other machinery or equipment, certain measures may be necessary. Please refer to one of the following manuals.

- MELSEC iQ-R Module Configuration Manual
- Safety Guidelines (This manual is included with the base unit.)

The CE mark on the side of the programmable controller indicates compliance with EMC and Low Voltage Directives.

Additional measures

To ensure that this product maintains EMC and Low Voltage Directives, please refer to one of the following manuals.

- MELSEC iQ-R Module Configuration Manual
- Safety Guidelines (This manual is included with the base unit.)

CONTENTS

COPYRIGHT	1
PRECAUTIONS REGARDING WARRANTY AND SPECIFICATIONS	1
SAFETY PRECAUTIONS	2
CONDITIONS OF USE FOR THE PRODUCT	10
INTRODUCTION	10
COMPLIANCE WITH EMC AND LOW VOLTAGE DIRECTIVES	11
RELEVANT MANUALS	13
TERMS	14
GENERIC TERMS AND ABBREVIATIONS	14
CHAPTER 1 PART NAMES	15
CHAPTER 2 SPECIFICATIONS	17
2.1 Performance Specifications	17
CHAPTER 3 FUNCTION LIST	19
CHAPTER 4 PROCEDURES BEFORE OPERATION	21
CHAPTER 5 SYSTEM CONFIGURATION	23
5.1 System Configuration of AnyWireASLINK	23
5.2 Power Supply to the AnyWireASLINK System	24
Method of supplying the power to the slave module	24
Scope of the power supply with transmission cables (DP and DN)	24
CHAPTER 6 WIRING	28
6.1 Terminal Block	28
6.2 Wiring Method	29
6.3 Wiring Product	31
6.4 Connecting Slave Module or Terminating Unit	32
CHAPTER 7 COMMUNICATION EXAMPLE	34
7.1 Communication of RJ51AW12AL with Slave Module	34
System configuration example	34
RJ51AW12AL setting	35
Settings of the slave module	37
Checking the system status	37
Program example	38
APPENDIX	40
Appendix 1 External Dimensions	40
INDEX	44
REVISIONS	46
WARRANTY	47
TRADEMARKS	48

RELEVANT MANUALS

Manual name [manual number]	Description	Available form
MELSEC iQ-R AnyWireASLINK Master Module User's Manual (Startup) [SH-081584ENG] (this manual)	Specifications, procedures before operation, system configuration, wiring, and communication examples of the AnyWireASLINK master module	Print book e-Manual PDF
MELSEC iQ-R AnyWireASLINK Master Module User's Manual (Application) [SH-081585ENG]	Functions, parameter settings, programming, troubleshooting, I/O signals, and buffer memory of the AnyWireASLINK master module	Print book e-Manual PDF
iQ Sensor Solution Reference Manual [SH-081133ENG]	Online operations of iQ Sensor Solution	Print book e-Manual PDF

This manual does not include detailed information on the following:

- General Specifications
- Applicable combinations of CPU modules and the other modules, and the number of mountable modules
- Installation

For details, refer to the following.

 MELSEC iQ-R Module Configuration Manual



e-Manual refers to the Mitsubishi FA electronic book manuals that can be browsed using a dedicated tool.

e-Manual has the following features:

- Required information can be cross-searched in multiple manuals.
- Other manuals can be accessed from the links in the manual.
- The hardware specifications of each part can be found from the product figures.
- Sample programs can be copied to an engineering tool.

TERMS

Unless otherwise specified, this manual uses the following terms.

Term	Description
Address	A setting value assigned to a slave module to identify each node on the AnyWireASLINK network
Address writer	A hand-held device to read/write device parameters (including addresses) from/to a slave module
AnyWireASLINK	A reduced wiring network where sensors at the end of a control system are connected to a programmable controller. This network enables a master module to detect sensor disconnection and enables a user to set the I/O operations of an AnyWireASLINK system on the RJ51AW12AL from the upper system without using the I/O areas of the CPU module.
Buffer memory	Memory in an intelligent function module for storing data such as setting values and monitored values.
Device	A device (X, Y, M, D, or others) in a CPU module
Engineering tool	Another term for the software package for the MELSEC programmable controllers
ID	A parameter to identify whether the module is an input module or output module based on its address
Intelligent function module	A module that has functions other than input and output, such as an A/D converter module and D/A converter module
Label	A label that represents a device in a given character string
Module label	A label that represents one of memory areas (I/O signals and buffer memory areas) specific to each module in a given character string. For the module used, GX Works3 automatically generates this label, which can be used as a global label.
Power cable (24V, 0V)	A cable that connects a 24VDC external power supply to the RJ51AW12AL. This cable is also used when the isolation (4-line) type slave module and RJ51AW12AL are connected.
RAS	An abbreviation for Reliability, Availability, and Serviceability. This term refers to usability of automated equipment.
Terminating unit	A waveform shaper
Transmission cable (DP, DN)	A signal cable that connects between a slave module and the RJ51AW12AL
Transmission cycle time	A data sampling interval

GENERIC TERMS AND ABBREVIATIONS

Unless otherwise specified, this manual uses the following generic terms and abbreviations.

Term	Description
ASLINKAMP	A generic term for sensor amplifiers that have an AnyWireASLINK interface
ASLINKER	A generic term for I/O devices that have an AnyWireASLINK interface
Bit slave module	A generic term for slave modules that communicate bit data only with the RJ51AW12AL. There are following types of bit slave module: <ul style="list-style-type: none">• Bit input slave module• Bit output slave module• Bit I/O combined slave module Some slave modules can be operated as a word slave module depending on the setting.
CPU module	A generic term for the MELSEC iQ-R series CPU modules
Slave module	A generic term for modules that communicate data with the RJ51AW12AL. There are following types of slave module: <ul style="list-style-type: none">• Bit slave module• Word slave module
Word slave module	A generic term for slave modules that communicate word data only with the RJ51AW12AL. There are following types of word slave module: <ul style="list-style-type: none">• Word input slave module• Word output slave module• Word I/O combined slave module Some slave modules can be operated as a bit slave module depending on the setting.

1 PART NAMES

This chapter describes the names of each part of the RJ51AW12AL.

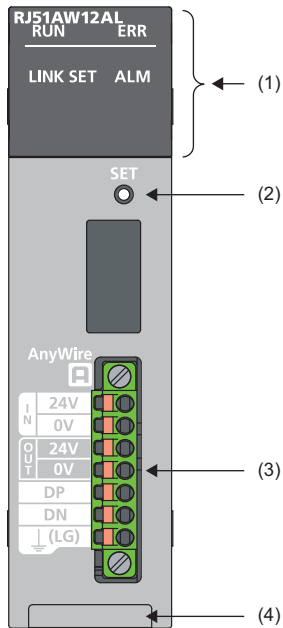

No.	Name	Description
(1)	RUN LED	Indicates the operating status. On: Normal operation Off: Error (MELSEC iQ-R AnyWireASLINK Master Module User's Manual (Application))
	ERR LED	Indicates the error status of the module. On, flashing: Error (MELSEC iQ-R AnyWireASLINK Master Module User's Manual (Application)) Off: Normal operation
	LINK LED* ¹	Indicates the link status. On: Communications not executed or during the AnyWireASLINK version compatibility inspection Flashing: Communications in progress Off: Communications not executed
	SET LED* ¹	Indicates the address detection status. On: Automatic address detection in progress or the EEPROM error Flashing: Address write in progress Off: Before or after automatic address detection
	ALM LED* ¹	Indicates the warning status. On: DP/DN disconnection, no response from the slave module, AnyWireASLINK version compatibility inspection error, or backup/restoring unsupported error Flashing (2-second intervals): DP-DN short circuit, 24V-DP short circuit Flashing (0.4-second intervals): A 24VDC power supply is not being supplied or the voltage is low. Off: Normal operation
(2)	SET switch	Switch for automatic detection of the slave module ID (address)
(3)	Transmission cable terminal block	A terminal block of the AnyWireASLINK (Page 28 Signal name of the terminal block)
(4)	Production information marking	Displays the production information of the module (16 digits).

*1 The initialization processing of the RJ51AW12AL is performed when the CPU module is reset or power off and on the system. At this time, the LINK LED, SET LED, and ALM LED turn on for an instant.

MEMO

2 SPECIFICATIONS

2.1 Performance Specifications

The following table lists the performance specifications of the RJ51AW12AL.

Item	Description	
Transmission clock	27.0kHz	
Maximum total wiring length	200m ^{*1}	
Transmission system	DC transmission line total frame cyclic transmission cyclic system	
Connection type	Bus topology (multidrop system, T-branch system, tree branch system)	
Transmission protocol	Dedicated protocol (AnyWireASLINK)	
Error control	Checksum, double-verification system	
Number of bit data points/number of word data points	<ul style="list-style-type: none"> Number of bit data points: 512 bits maximum (input 256 bits/output 256 bits) Number of word data points: 1024 words maximum (input 512 words/output 512 words)^{*4} 	
Number of connected slave modules	128 maximum (varies depending on the current consumption of each slave module)	
External interface (power supply part/communication part)	Push-in type 7-piece spring clamp terminal block (☞ Page 28 Terminal Block)	
Transmission cable (DP, DN) ^{*3}	<ul style="list-style-type: none"> UL-listed general-purpose 2-wire cable (VCTF, VCT 1.25mm², 0.75mm², temperature rating 70°C or higher) UL-listed general-purpose wire (1.25mm², 0.75mm², temperature rating 70°C or higher) Dedicated flat cable (1.25mm², 0.75mm², temperature rating 90°C) 	
Power supply cable (24V, 0V) ^{*3}	<ul style="list-style-type: none"> UL-listed general-purpose 2-wire cable (VCTF, VCT 0.75mm² to 2.0mm², temperature rating 70°C or higher) UL-listed general-purpose wire (0.75mm² to 2.0mm², temperature rating 70°C or higher) Dedicated flat cable (1.25mm², 0.75mm², temperature rating 90°C) 	
Applicable solderless terminal	<ul style="list-style-type: none"> Processing of a 1.25mm² wire: AI 1,5-8 BK Processing of a 0.75mm² wire: AI 0,75-8 GY 	
Transmission cable supply current ^{*2}	<ul style="list-style-type: none"> When using a 1.25mm² cable: 2A maximum When using a 0.75mm² cable: 1.2A maximum 	
Maximum number of writes to EEPROM	100000 times maximum	
Internal current consumption (5VDC)	0.2A	
External power supply	Voltage: 21.6 to 27.6VDC (24VDC -10 to +15%), ripple voltage 0.5Vp-p or lower Recommended voltage: 26.4VDC (24VDC +10%) Transmission cable supply current: 2A maximum ^{*2}	
Number of occupied I/O points	32 points (I/O assignment: intelligent 32 points)	
External dimensions	Height	106mm (base unit mounting part: 98mm)
	Width	27.8mm
	Depth	124mm
Weight	0.13kg	

*1 For slave modules with transmission cables (DP, DN), the length of the transmission cables (DP, DN) is included in the total wiring length.

For wiring of 50m or more with 4 wires (DP, DN, 24V, 0V), insert the noise filter for power supply cables between the power supply and cables. For details, refer to the manual for the AnyWireFILTER (ANF-01) manufactured by Anywire Corporation.

*2 For the relation of the total wiring length, wire diameter of transmission cables (DP, DN), and transmission cable supply current, refer to the following.

On some slave modules with cables, the wire diameter of module-integrated transmission cables (DP, DN) may be smaller than 0.75mm². However, they can be used without any problem, provided that the wire diameter of transmission cables (DP, DN) meets the following requirements.

Wire diameter of transmission cables (DP, DN)	Transmission cable supply current		
	Total wiring length of 50m or less	Total wiring length of 50 to 100m	Total wiring length of 100 to 200m
1.25mm ²	2A maximum	1A maximum	0.5A maximum
0.75mm ²	1.2A maximum	0.6A maximum	0.3A maximum

*3 When the operating ambient temperature is 50°C or higher, use cables with a temperature rating 75°C or higher.

*4 The performance specification differs depending on the production information of the RJ51AW12AL. (☞ MELSEC iQ-R AnyWireASLINK Master Module User's Manual (Application))

3 FUNCTION LIST

This chapter describes the functions of the RJ51AW12AL. For details on the functions, refer to the following.

📖 MELSEC iQ-R AnyWireASLINK Master Module User's Manual (Application)

AnyWireASLINK transmission

Function	Description
Bit transmission	Exchanges I/O data of maximum 512 bits (input 256 bits, output 256 bits) between the RJ51AW12AL and a slave module.
Word transmission ^{*1}	Exchanges I/O data of maximum 1024 words (input 512 words, output 512 words) between the RJ51AW12AL and a slave module.
Double verification	A double verification is an error control system. In this system, cycle data in AnyWireASLINK transmission is recognized as valid data if the data matches with the data of the last transmission or is ignored as invalid data if the data does not match with the last data. A double verification ensures reliability of communication.
Slave module parameter read/write	In AnyWireASLINK, parameter information of a slave module and the AnyWireASLINK system in addition to I/O information are sent and received between the RJ51AW12AL and a slave module. Execute this function to check or change parameter information of a slave module.

*1 The availability of the function differs depending on the production information of the RJ51AW12AL. (📖 MELSEC iQ-R AnyWireASLINK Master Module User's Manual (Application))

Address setting

Function	Description
Automatic address detection function	Enables the RJ51AW12AL to detect and store the ID (address) of the connected slave module when the SET switch on the RJ51AW12AL is pressed.
Remote address change function	Changes an ID (address) of a slave module using the buffer memory area without an address writer.
Same ID used detection function	Checks whether the same ID is used for multiple slave modules through automatic address detection or same address used check. The LEDs of the relevant slave modules are forcibly turned on.
Module with no ID setting detection function	Detects slave modules with no ID assigned (default ID) through automatic address detection or same address used check.

RAS

Function	Description
Transmission cable short detection function	Protects the system by detecting the current out of the specifications of the AnyWireASLINK system across DP-DN or 24V-DP and stopping the transmission.
Disconnected transmission cable location detection function	Notifies the ID of a slave module that has been separated from the RJ51AW12AL because of disconnection in the transmission cables (DP, DN) between the RJ51AW12AL and the slave module, to locate the disconnection in the transmission cables (DP, DN) from the upper system.
Transmission cable voltage drop detection function	Detects a voltage drop in the 24VDC external power supply, enabling the RJ51AW12AL to detect a failure in the 24VDC external power supply or a wiring error from the upper system.

Others

Function	Description
Parameter access error detection function	Allows parameter access errors to be detected.
Error status automatic recovery function	Allows for automatically clearing error flag for DP/DN disconnection errors and parameter access errors after the error status is cleared.
Slave module information acquisition function at start-up	Allows for automatic acquisition of information of slave modules when the CPU module is reset or power off and on the system.
Backup/restoring function	Backs up various information of the connected slave module into the SD memory card of the CPU module. This function restores the information backed up on the SD memory card of the CPU module into the connected slave module. For details, refer to the following.  iQ Sensor Solution Reference Manual
Easy replacement function for one slave module ^{*1}	Allows for automatically setting addresses and device parameters without an address writer when a slave module is replaced with the same type of it.
Word data start address setting function ^{*1}	Allows for setting start addresses of word data transmission. This function shortens the word transmission cycle time.
AnyWireASLINK version compatibility inspection function ^{*1}	Inspects whether a slave module that does not support the word transmission is connected to the RJ51AW12AL or not.

*1 The availability of the function differs depending on the production information of the RJ51AW12AL. ( MELSEC iQ-R AnyWireASLINK Master Module User's Manual (Application))

4 PROCEDURES BEFORE OPERATION

This chapter describes the procedures before operation.

1. Configuring a system

Configure an AnyWireASLINK system and set parameters which are required for start-up.

- WIRING (📖 Page 28 WIRING)
- Parameter setting (📖 MELSEC iQ-R AnyWireASLINK Master Module User's Manual (Application))
- Address setting of slave modules (📖 MELSEC iQ-R AnyWireASLINK Master Module User's Manual (Application))
- Automatic address detection function (📖 MELSEC iQ-R AnyWireASLINK Master Module User's Manual (Application))

2. Powering on the system

Power on and start the system in the order shown below.

- Turn on the 24VDC external power supply for the AnyWireASLINK system.
- Turn on the power supply of the programmable controller.

3. Checking operations with the LEDs

Check whether communications are established normally.

When the communications are established normally, the following LED on/off statuses are as follows.

- RUN LED: On
- ERR LED: Off
- LINK LED: Flashing
- SET LED: Off
- ALM LED: Off

4. Programming

Create a program. For details, refer to the following.

📖 Page 34 COMMUNICATION EXAMPLE

Point

- If the programmable controller is powered on before the 24VDC external power supply in the AnyWireASLINK system, a transmission cable voltage drop detection error may occur.
 - To power off the system, power off the programmable controller, and turn off the 24VDC external power supply in the AnyWireASLINK system.
-

MEMO

5 SYSTEM CONFIGURATION

5.1 System Configuration of AnyWireASLINK

An AnyWireASLINK system consists of the RJ51AW12AL, slave modules, and a terminating unit. The slave modules and a terminating unit are products manufactured by Anywire Corporation.

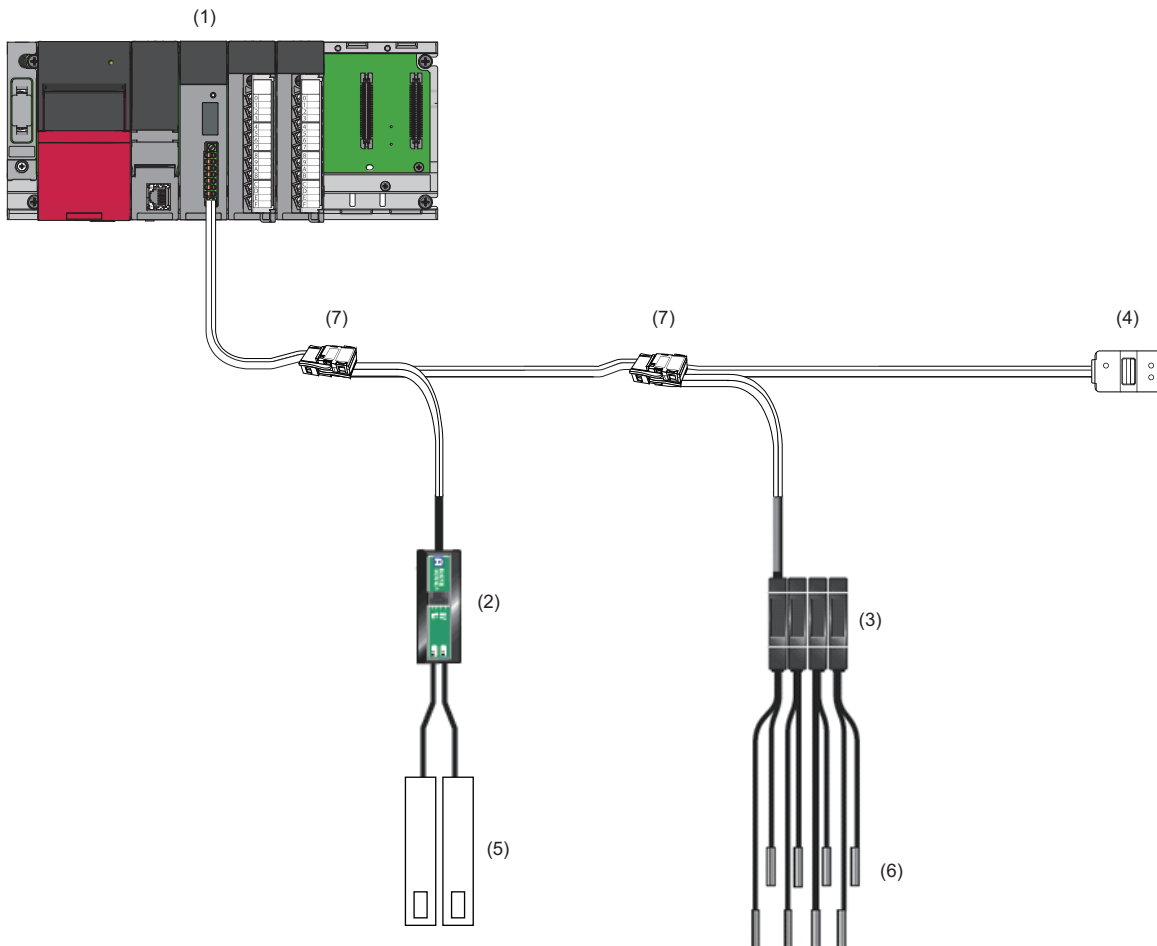

- (1) RJ51AW12AL
- (2) Slave module (ASLINKER)
- (3) Slave module (ASLINKAMP)
- (4) Terminating unit
- (5) Cylinder, switch, or others
- (6) Sensor head
- (7) Link connector

For the number of connectable slave modules, refer to the following.

Page 17 Performance Specifications



For applicable CPU modules and the number of mountable modules, refer to the following.

MELSEC iQ-R Module Configuration Manual

5.2 Power Supply to the AnyWireASLINK System

Method of supplying the power to the slave module

Connect a 24VDC external power supply to the RJ51AW12AL.

The power consumed in the internal control circuits of all the slave modules and the external load power connected to non-isolation slave modules are supplied collectively from the 24VDC external power supply connected to the RJ51AW12AL.

(☞ Page 17 Performance Specifications)

Scope of the power supply with transmission cables (DP and DN)

The current consumption of the system must satisfy all the following conditions for the RJ51AW12AL.

Item	Calculation formula	Description
Condition 1	$I(A) = (I_{hin} \times m) + (I_{ho} \times n) + (I_{zdin} \times p) + (I_{zdo} \times q) \leq$ The maximum value of transmission cable supply current	<p>I_{hin}: Current consumption of the non-isolation input slave module/I/O combined slave module</p> <p>I_{ho}: Current consumption of the non-isolation output slave module</p> <p>I_{zdin}: Current consumption of the isolation input slave module/I/O combined slave module</p> <p>I_{zdo}: Current consumption of the isolation output slave module</p> <p>m: Number of connected non-isolation input slave modules/I/O combined slave modules</p> <p>n: Number of connected non-isolation output slave modules</p> <p>p: Number of connected isolation input slave modules/I/O combined slave modules</p> <p>q: Number of connected isolation output slave modules</p>
Condition 2	$V_m(V) - \Delta V(V) \geq 20V$	V_m : Supply voltage for the RJ51AW12AL
Condition 3	$V_m(V) - \Delta V(V) \geq$ The lowest allowable voltage of the connected load	ΔV : Cable-to-cable voltage drop

Description of the condition 1

■ Constants related to the non-isolation slave module (I_{hin}, I_{ho})

In the non-isolation slave module, the current required for the internal control circuit and the connected load is supplied with transmission cables (DP, DN).

■ I_{hin}(A): Current consumption of the non-isolation input slave module//O combined slave module

= Current consumption of the non-isolation input slave module//O combined slave module + Current consumption of connected load (three-wire sensor) × Number of points

■ I_{ho}(A): Current consumption of the non-isolation output slave module

= Current consumption of the non-isolation output slave module + Current consumption of connected load × Number of points

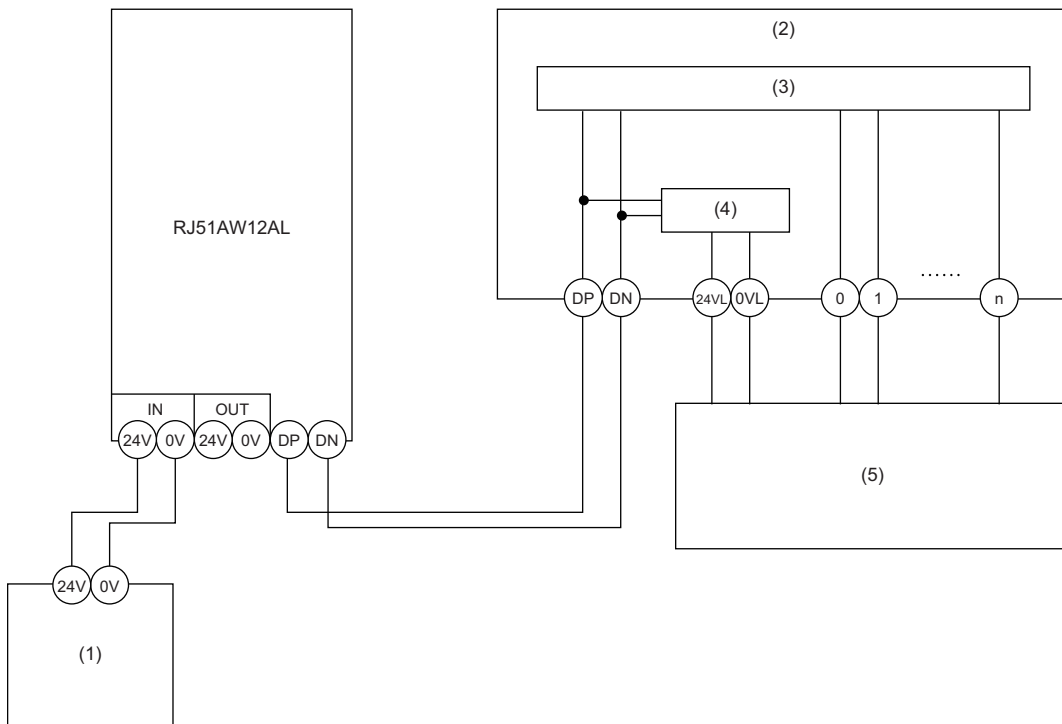

(1) 24VDC external power supply

(2) Non-isolation slave module

(3) Internal control circuit

(4) Power supply generation

(5) Connected load

Point

- The 24VL and 0VL terminals of a slave module are used to supply the power to the connected load.
- For the current consumption of a non-isolation slave module, refer to the manual for the slave module used.

■ Constants related to the isolation slave module (Izdin, Izdo)

In the isolation slave module, only the current required for the internal control circuit is supplied with the transmission cables (DP, DN), whereas that for the connected load is supplied from the power cables (24V, 0V).

■Izdin(A): Current consumption of the isolation input slave module/I/O combined slave module

■Izdo(A): Current consumption of the isolation output slave module

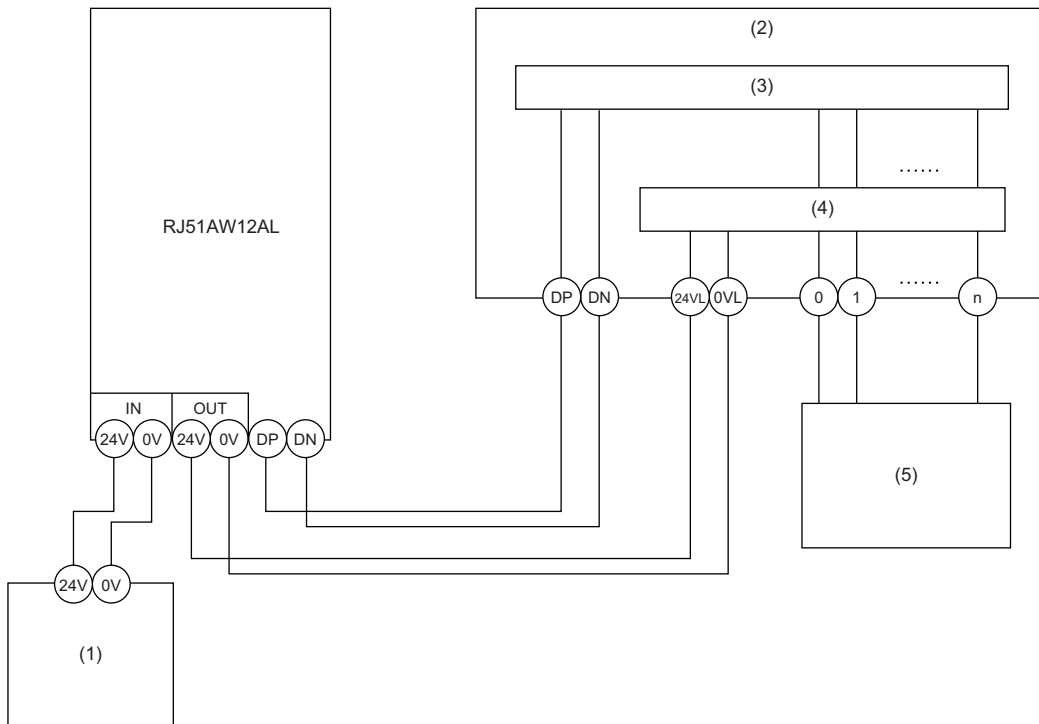

- (1) 24VDC external power supply
- (2) Isolation slave module
- (3) Internal control circuit
- (4) Load driving circuit (photocoupler)
- (5) Connected load

Point

- In isolation slave modules, the current consumption of the connected load is not subject to the current restriction condition for the AnyWireASLINK system.
- For the current consumption of isolation slave modules, refer to the manual for the slave module used.

■ Transmission cable supply current (I(A))

The transmission cable supply current in the AnyWireASLINK system is determined by the following formula. (Number of connected modules: m, n, p, q)

$$I(A) = (I_{hin} \times m) + (I_{ho} \times n) + (I_{zdin} \times p) + (I_{zdo} \times q)$$

■ Maximum transmission cable supply current

For the maximum transmission cable supply current, refer to the following.

☞ Page 17 Performance Specifications

Description of the conditions 2 and 3

■Vm: Supply voltage for the RJ51AW12AL

- Voltage: 21.6 to 27.6VDC (24VDC -10 to +15%), ripple voltage 0.5Vp-p or lower
- Recommended voltage: 26.4VDC (24VDC +10%)

■ΔV(V): Cable-to-cable voltage drop

Calculation formula	Description
$\Delta V(V) = \text{Transmission cable supply current } I(A) \times \text{Cable resistance } R(\Omega)$	<ul style="list-style-type: none"> ■Transmission cable supply current (I(A)) <ul style="list-style-type: none"> ☞ Page 26 Transmission cable supply current (I(A)) ■Cable resistance R (Ω) <ul style="list-style-type: none"> = Cable length (m) × Conductor resistance (Ω/m) × 2 • Wire diameter 1.25mm² → Conductor resistance 0.015Ω/m • Wire diameter 0.75mm² → Conductor resistance 0.025Ω/m

Calculation example

The example shows how to check whether the total wiring length of 100m is sufficient to configure a system in the following conditions.

■Condition

Item	Description	
Non-isolation bit input slave module (ASLINKER)	Number of bit data points	2 points
	Module current consumption	15mA
	Number of modules	24
Connected load (three-wire sensor)	Three-wire sensor current consumption	13mA
	Number of sensors	2
	Power supply voltage	24VDC ±10%
Transmission cable (DP, DN)	Wire diameter	1.25mm ²
Supply voltage for the RJ51AW12AL	Power supply voltage	24VDC

■Calculation result

Item	Calculation formula	Result
Condition 1	$I(A) = (I_{hin} \times m) = I(A) \leq \text{The maximum transmission cable supply current}$ $\Rightarrow (0.015 + (0.013 \times 2)) \times 24 = 0.984A \leq 1A$	Satisfied
Condition 2	$V_m(V) - \Delta V(V) \geq 20V$ $\Rightarrow 24 - (0.984 \times 100 \times 0.015 \times 2) = 24 - 2.95 = 21.05V \geq 20V$	Satisfied
Condition 3	$V_m(V) - \Delta V(V) \geq \text{The lowest allowable voltage of the connected load}$ $\Rightarrow \text{The lowest limit of the allowable voltage range for connected load} = 24 - 24 \times 0.1 = 21.6V$ $\Rightarrow 21.05V < 21.6V$	Not satisfied

The calculation results of the conditions 1) to 3) show that the system cannot be configured.

However, the system can be configured if the power supply for the RJ51AW12AL is changed to 24.55VDC or higher.

6 WIRING

This chapter describes the wiring of the RJ51AW12AL.

6.1 Terminal Block

Type of the terminal block

The following terminal block is used in the RJ51AW12AL.

Name	Model	Contact
Transmission cable terminal block	FMC1,5/7-STF-3,81	PHOENIX CONTACT GmbH & Co. KG (www.phoenixcontact.com)

Tightening torque

Tighten terminal block screws within the following tightening torque range.

Screws tightened	Tightening torque range
Terminal block mounting screw	0.2 to 0.3N·m

To connect the terminal block, a flathead screwdriver having a tipped size of 0.4×2.5mm is required.

Before removing the transmission cable terminal block, check that the terminal block mounting screws on the both sides are completely loosened (removed from the socket).

Pulling with excessive force while the terminal block mounting screws on the both sides are still tightened may damage the devices.

Before tightening, check that there are no short circuits due to the disconnected or frayed wires. Then tighten the terminal block mounting screws on the both sides securely.

Signal name of the terminal block

The following shows the signal names of the terminal block.

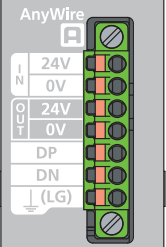
Terminal block	Signal name	Description	
	IN	24V	Power supply terminals for driving the transmission circuit of the AnyWireASLINK system and for a slave module. Connect to a 24VDC external power supply.
		0V	
	OUT	24V	Terminals for connecting isolation (4-wire) slave modules. If the modules are connected to these terminals, supplying power for each module from the 24VDC external power supply is not necessary.
		0V	
	DP	AnyWireASLINK transmission signal terminals	
	DN	DP: Transmission cable (+), DN: Transmission cable (-) Connect to the DP and DN terminals on the slave module or terminating unit.	
LG	Connected to the neutral point of the noise filter inserted between the 24V and 0V terminals. Ground the LG terminal with the functional ground terminal (FG terminal) on the programmable controller at a single point.		

6.2 Wiring Method

This section describes the wiring to the transmission cable terminal block of the RJ51AW12AL.

Wiring to the transmission cable terminal block

■Connecting a cable

Insert a cable with a bar solderless terminal into a wire insertion opening and fully push the cable. Then, pull the cable slightly to check that it is clamped securely.

■Disconnecting a cable

Hold down the open/close button of a cable to disconnect with a flathead screwdriver. Pull out the cable with the open/close button held down.

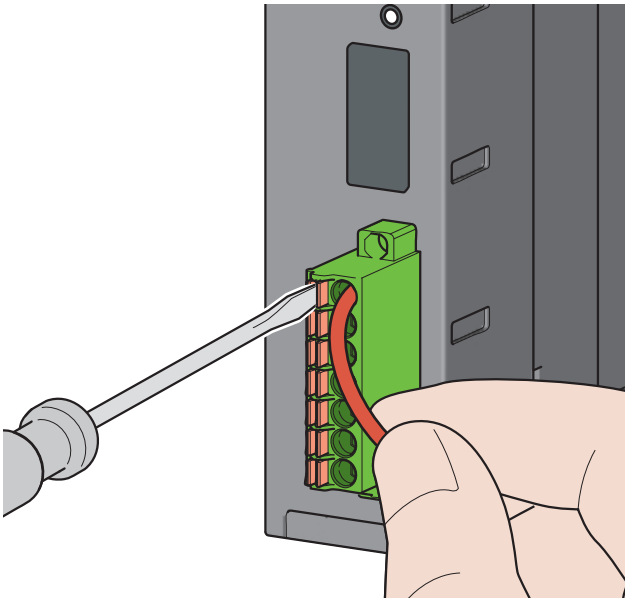

Precautions

- In the AnyWireASLINK system, signals and power are supplied to a slave module with two transmission cables: DP and DN. Therefore, use a stranded wire of 1.25mm² or larger as the main line.
- Wires such as general-purpose wires, cabtyre cables, and flat cables can be used.
- Do not run multiple transmission cables (DP, DN) using a multicore cable. Run multiple transmission cables (DP, DN) are affected by noise, causing a malfunction.

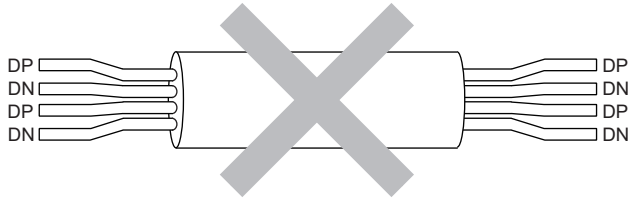

- The voltage should not fall below the lower limit of the allowable voltage range due to a voltage drop caused by the cable. If the voltage falls below the lower limit, malfunctions may occur.
- Do not connect soldered cables directly to the terminals. Doing so may loosen the screws, resulting in a poor contact.
- Use bar solderless terminals for the wiring to the terminal block. If inserted as is, a stripped cable cannot be clamped properly in a wire insertion opening.
- Use a crimping tool to connect a bar solderless terminal to a cable.
- Before inserting a bar solderless terminal, check the shapes of the wire insertion opening and bar solderless terminal. Then, insert the terminal in the correct orientation. A bar solderless terminal wider than the wire insertion opening may damage the terminal block. (➔ Page 31 Solderless terminal)
- Signal names are not printed on the transmission cable terminal block. To avoid incorrect wiring, wire cables to the terminal block attached to the RJ51AW12AL.
- Do not insert multiple bar solderless terminals into one wire insertion opening. Doing so may cause damage on the terminal block or cable, or malfunction.

6.3 Wiring Product

Applicable wires and cables

Use the following wires or cables connected to the transmission cable terminal block.

Classification	Name	Wire diameter	Type	Material	Temperature rating
Transmission cable (DP, DN)	UL-listed general-purpose 2-wire cable (VCTF, VCT)	1.25mm ²	Stranded wire	Copper wire	70°C or higher
		0.75mm ²			
	UL-listed general-purpose wire	1.25mm ²			
		0.75mm ²			
	Dedicated flat cable	1.25mm ²			90°C
		0.75mm ²			
Power supply cable (24V, 0V)	UL-listed general-purpose 2-wire cable (VCTF, VCT)	0.75mm ² to 2.0mm ²	Stranded wire	Copper wire	70°C or higher
		UL-listed general-purpose wire	0.75mm ² to 2.0mm ²		
	Dedicated flat cable		1.25mm ²		Stranded wire
		0.75mm ²			

Solderless terminal

Bare cables can be connected to the transmission cable terminal block; however, for safety reasons, it is recommended to connect bar solderless terminals.

Use UL-listed solderless terminals and, for processing, use a tool recommended by their manufacturer.

Type	Model	Application	Contact
Bar solderless terminal	AI 0,75-8 GY	Processing of a 0.75mm ² wire	PHOENIX CONTACT GmbH & Co. KG (www.phoenixcontact.com)
	AI 1,5-8 BK	Processing of a 1.25mm ² wire	

6.4 Connecting Slave Module or Terminating Unit

Connection type

- The distance in an AnyWireASLINK stand-alone system is 200m, which is the total wiring length including the main line and branch line. (It varies depending on the wire diameter of the transmission cables (DP, DN) or the transmission cable supply current.)
- AnyWireASLINK systems support tree branch connection, T-branch connection, and multidrop connection.
- Up to 128 slave modules can be connected.

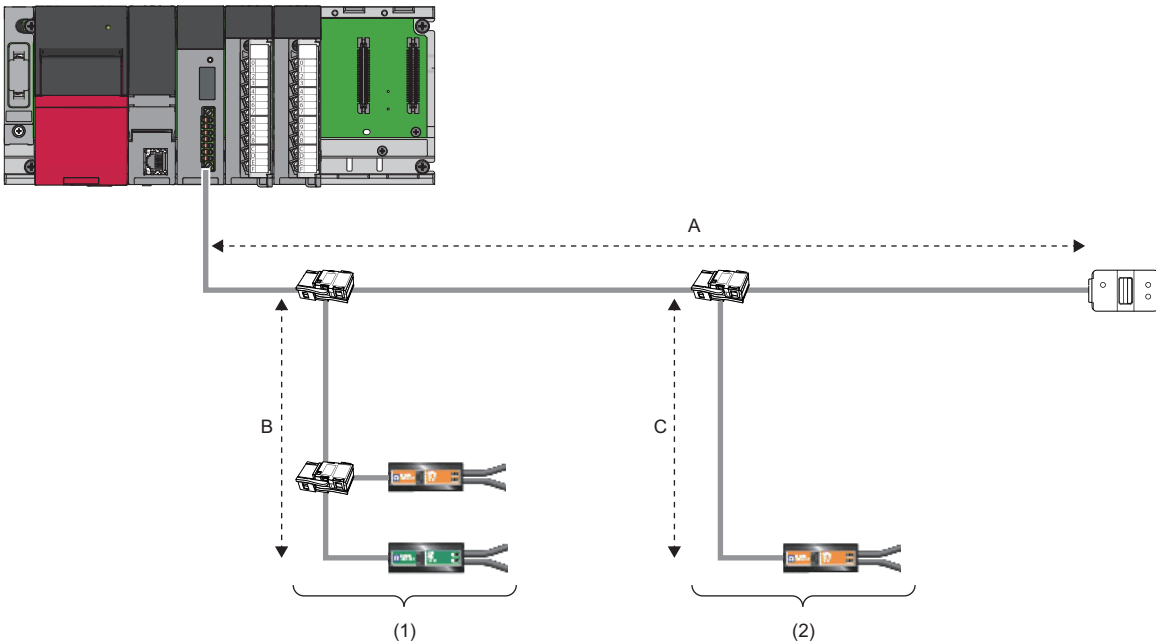

(1) Tree branch connection
(2) T-branch connection

Point

The total wiring length of the transmission distance for the AnyWireASLINK system can be calculated from $A + B + C$.
Note that the total length should not exceed the total wiring length set for the system to branch lines.

Terminating unit

To ensure more stable transmission quality, connect a terminating unit to the end of a transmission cable (DP, DN).

■Terminating unit connection

Connect at least one terminating unit for one AnyWireASLINK line. Connect it at the farthest end from the RJ51AW12AL. The maximum number of connectable modules differs depending on the terminating unit used. For details, refer to user's manuals for the terminating unit used.

■Branch of transmission cables (DP, DN)

Connect one terminating unit at the end of a branch line that exceeds 40m.

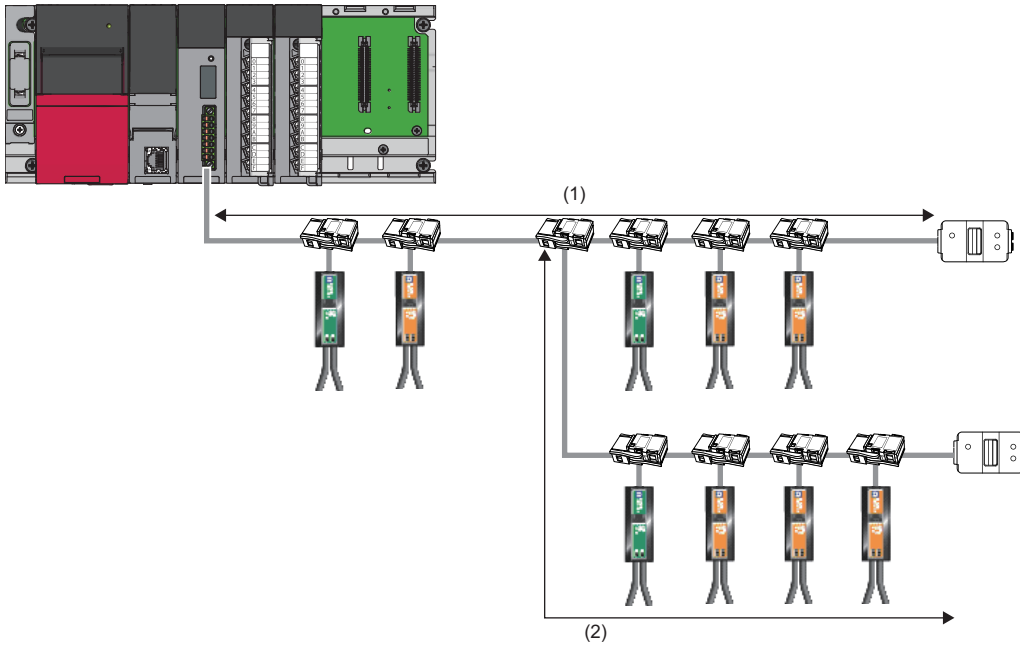

(1) Main line

(2) 40m or longer branch line

7 COMMUNICATION EXAMPLE

This chapter describes programming and start-up examples of the RJ51AW12AL.

7.1 Communication of RJ51AW12AL with Slave Module

The input signals of the input ASLINKER, stored in 'Bit input information area' (Un\G0 to Un\G15) of the RJ51AW12AL, are batch-transferred to the device data of the CPU module.

Moreover, the device data of the CPU module is batch-transferred to 'Bit output information area' (Un\G4096 to Un\G4111) of the RJ51AW12AL, and the output signals are transmitted to the output ASLINKER.

System configuration example

System configuration

The following system configuration is used to describe communication between the RJ51AW12AL and bit slave modules.

- Power supply module: R61P
- CPU module: R04CPU
- AnyWireASLINK master module: RJ51AW12AL (start I/O number: 0000H to 001FH)

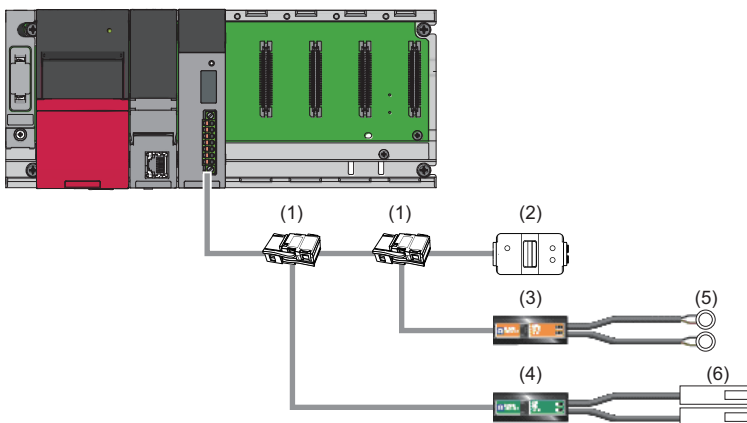

- (1) Link connector
- (2) Terminating unit
- (3) 2-point output ASLINKER
- (4) 2-point input ASLINKER
- (5) LED
- (6) Sensor switch

Correlations between devices

The following shows the correlations between devices.

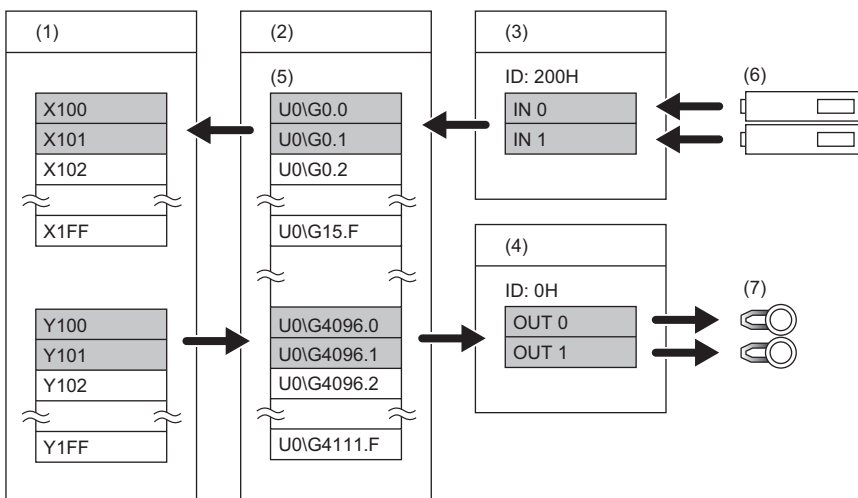

- (1) CPU module
- (2) RJ51AW12AL
- (3) Input ASLINKER: Address 0
- (4) Output ASLINKER: Address 0
- (5) Buffer memory
- (6) Sensor switch
- (7) LED

RJ51AW12AL setting

Connect the engineering tool to the CPU module and set parameters.

1. Set the CPU module as follows.

[Project] ⇒ [New]

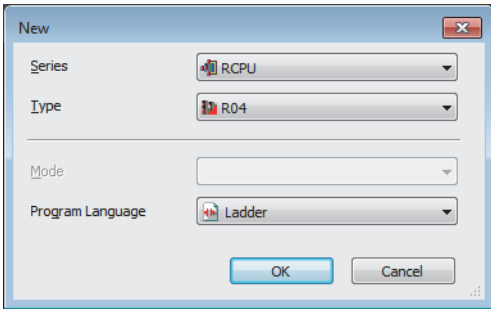

2. Click the [OK] button to add the module labels of the CPU module.

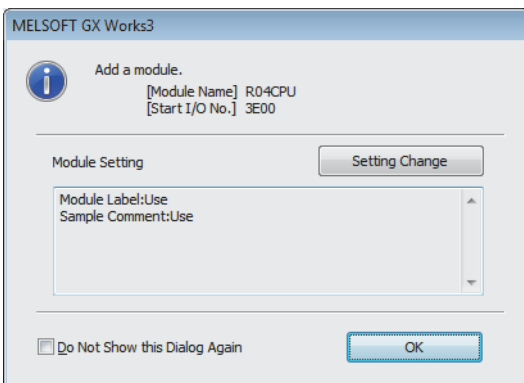

3. Set the RJ51AW12AL as follows.

[Navigation window] ⇒ [Parameter] ⇒ [Module Information] ⇒ Right-click ⇒ [Add New Module]

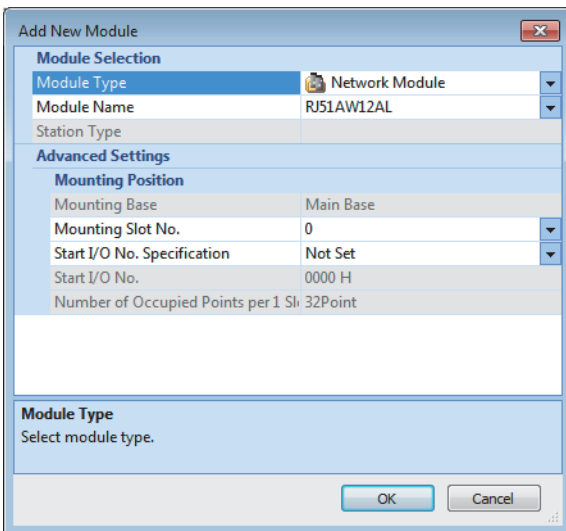

4. Click the [OK] button to add the module labels of the RJ51AW12AL.

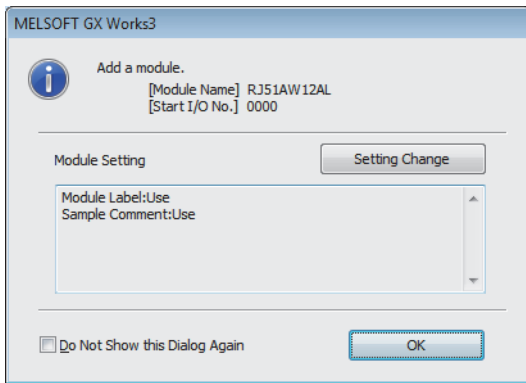

5. Set the items in "Basic setting" as follows.

[Navigation window] ⇒ [Parameter] ⇒ [Module Information] ⇒ [RJ51AW12AL] ⇒ [Module Parameter] ⇒ [Basic Settings]

Item	Setting Value
Transmission points	
Transmission points setting	3: 512 points(256 input points/256 output points)
Startup operating mode	
Startup operating mode setting	0: Without slave information acquisition
Double verification	
Double verification setting	0: All points, double verification of a bit
Error status automatic recovery	
Error status automatic recovery mode setting	0: No error status automatic recovery
Output data hold/clear setting when error occurs	
Output data hold/clear setting when error occurs	0: CLEAR
Word input data hold/clear setting when error occurs	
Word input data hold/clear setting when error occurs	0: CLEAR
Easy replacement enable/disable setting for one slave mod	
Easy replacement enable/disable setting for one slave mod	0: Enable
Word data points setting	
To use or not to use word data setting	0: Not use
Word data points setting	0: word data (no word data)
Word data start address	0
Word data points setting per frame	0: word data (no word data)

6. Write the set parameters into the CPU module, and reset the CPU module or power off and on the system.

[Online] ⇒ [Write to PLC]

Point

In this example, default values were used for parameters that are not shown above. For the parameters, refer to the following.

📖 MELSEC iQ-R AnyWireASLINK Master Module User's Manual (Application)

Settings of the slave module

Write addresses to slave modules to register the RJ51AW12AL.

Address setting

Write addresses to slave modules with an address writer.

- Output ASLINKER: Address 0 (ID: 0000H)
- Input ASLINKER: Address 0 (ID: 0200H)

Automatic address detection

Keep pressing the SET switch on the RJ51AW12AL until the SET LED turns on.

When the SET LED flashes and then turns off, it indicates that the registration of IDs (addresses) has been completed.

Checking the system status

Check whether the RJ51AW12AL can communicate with the slave modules normally.

The following LED statuses indicate that the communication is established normally.

- LED of the RJ51AW12AL

LED	Status
RUN LED	On
ERR LED	Off
LINK LED	Flashing
SET LED	Off
ALM LED	Off

- LED of the ASLINKER

LED	Status
LINK LED	Flashing
ALM LED	Off

Program example

Classification	Label name	Description	Device
Module label	RJ51AW12AL_1.bModuleREADY	Module READY	X0
	RJ51AW12AL_1.bDP_DNShortError	DP/DN short error	X1
	RJ51AW12AL_1.b24V_DPShortError	24V/DP short error	X2
	RJ51AW12AL_1.bTransmissionCableVoltageDdropError	Transmission cable voltage drop error	X3
	RJ51AW12AL_1.bDP_DNDisconnectionError	DP/DN disconnection error	X4
	RJ51AW12AL_1.uInputInformationArea0_15	Bit input information area	U0\G0
	RJ51AW12AL_1.uOutputInformationArea0_15	Bit output information area	U0\G4096

Label to be defined	Define the global label as follows.
---------------------	-------------------------------------

Label Name	Data Type	Class	Assign (Device/Label)
TimerContact	Timer	VAR_GLOBAL	T0
ProgramStart	Bit	VAR_GLOBAL	M1
InputArea	Word [Signed]	VAR_GLOBAL	K4X100
OutputArea	Word [Signed]	VAR_GLOBAL	K4Y100

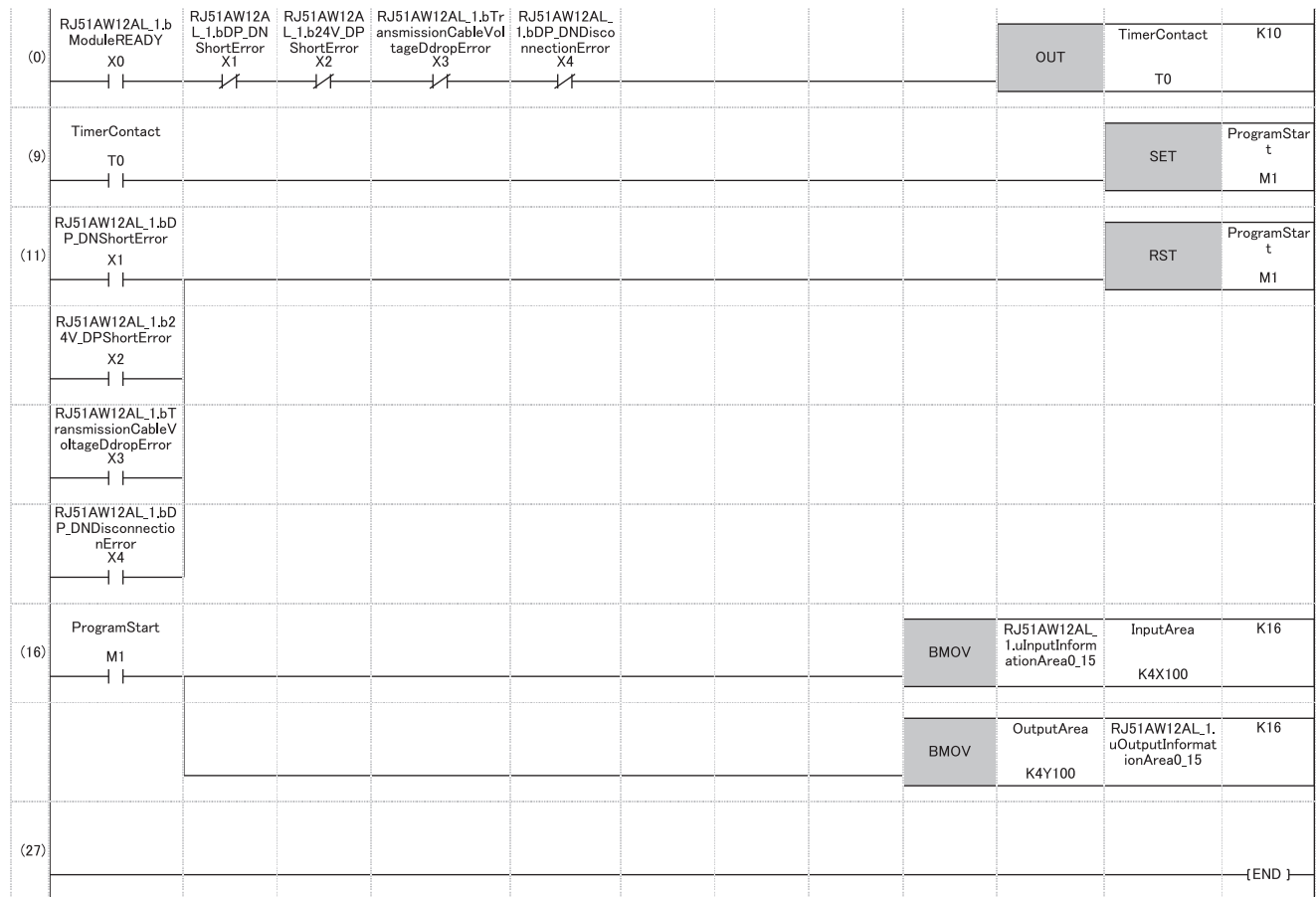

- (16) When 'ProgramStart' (M1) is turned on, the values of 'Bit input information area' (U0\G0) are transferred to 'Input ASLINKER data storage area' (K4X100).
The values of 'Output ASLINKER data storage area' (K4Y100) are transferred to 'Bit output information area' (U0\G4096).



After 'Module READY' (X0) turns on, wait at least one second and start the program.

APPENDIX

Appendix 1 External Dimensions

This chapter describes the external dimensions of the RJ51AW12AL.

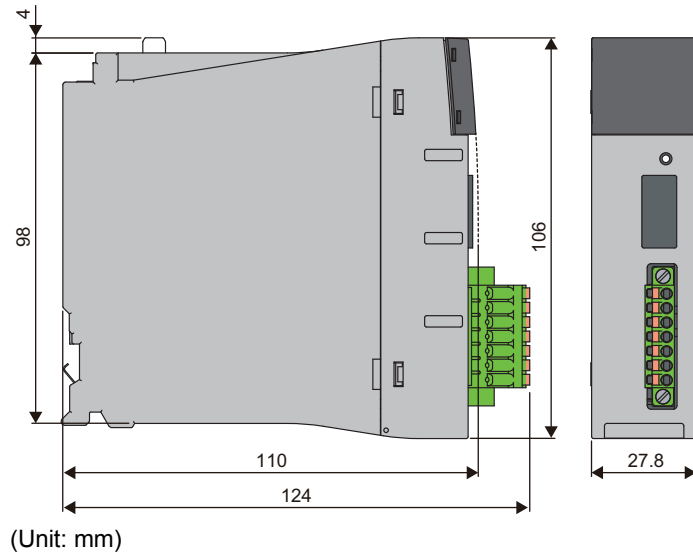

MEMO

A

MEMO

MEMO

A

INDEX

A

Address	14
AnyWireASLINK	14

B

Bar solderless terminal	31
-----------------------------------	----

D

Device	14
------------------	----

E

Engineering tool	14
External dimensions	17
External power supply	17

I

ID	14
Intelligent function module	14
Internal current consumption (5VDC)	17

L

Label	14
-----------------	----

M

Module label	14
------------------------	----

P

Power supply cable (24V, 0V)	31
--	----

R

RAS	14
---------------	----

S

Solderless terminal	31
-------------------------------	----

T

T-branch	32
Terminating unit	14
Transmission cable (DP, DN)	31
Transmission cable terminal block	28
Tree branch	32

W

Weight	17
------------------	----

MEMO

REVISIONS

*The manual number is given on the bottom left of the back cover.

Revision date	*Manual number	Revision
June 2016	SH(NA)-081584ENG-A	First edition
November 2016	SH(NA)-081584ENG-B	■Added or modified parts SAFETY PRECAUTIONS, RELEVANT MANUALS, Chapter 3
April 2019	SH(NA)-081584ENG-C	■Added or modified parts RELEVANT MANUALS, TERMS, Chapter 1,2,3, Section 5.1, 5.2, 6.4

Japanese manual number: SH-081582-C

This manual confers no industrial property rights or any rights of any other kind, nor does it confer any patent licenses. Mitsubishi Electric Corporation cannot be held responsible for any problems involving industrial property rights which may occur as a result of using the contents noted in this manual.

© 2016 MITSUBISHI ELECTRIC CORPORATION

WARRANTY

Please confirm the following product warranty details before using this product.

1. Gratis Warranty Term and Gratis Warranty Range

If any faults or defects (hereinafter "Failure") found to be the responsibility of Mitsubishi occurs during use of the product within the gratis warranty term, the product shall be repaired at no cost via the sales representative or Mitsubishi Service Company.

However, if repairs are required onsite at domestic or overseas location, expenses to send an engineer will be solely at the customer's discretion. Mitsubishi shall not be held responsible for any re-commissioning, maintenance, or testing on-site that involves replacement of the failed module.

[Gratis Warranty Term]

The gratis warranty term of the product shall be for one year after the date of purchase or delivery to a designated place. Note that after manufacture and shipment from Mitsubishi, the maximum distribution period shall be six (6) months, and the longest gratis warranty term after manufacturing shall be eighteen (18) months. The gratis warranty term of repair parts shall not exceed the gratis warranty term before repairs.

[Gratis Warranty Range]

- (1) The range shall be limited to normal use within the usage state, usage methods and usage environment, etc., which follow the conditions and precautions, etc., given in the instruction manual, user's manual and caution labels on the product.
- (2) Even within the gratis warranty term, repairs shall be charged for in the following cases.
 1. Failure occurring from inappropriate storage or handling, carelessness or negligence by the user. Failure caused by the user's hardware or software design.
 2. Failure caused by unapproved modifications, etc., to the product by the user.
 3. When the Mitsubishi product is assembled into a user's device, Failure that could have been avoided if functions or structures, judged as necessary in the legal safety measures the user's device is subject to or as necessary by industry standards, had been provided.
 4. Failure that could have been avoided if consumable parts (battery, backlight, fuse, etc.) designated in the instruction manual had been correctly serviced or replaced.
 5. Failure caused by external irresistible forces such as fires or abnormal voltages, and Failure caused by force majeure such as earthquakes, lightning, wind and water damage.
 6. Failure caused by reasons unpredictable by scientific technology standards at time of shipment from Mitsubishi.
 7. Any other failure found not to be the responsibility of Mitsubishi or that admitted not to be so by the user.

2. Onerous repair term after discontinuation of production

- (1) Mitsubishi shall accept onerous product repairs for one year after production of the product is discontinued. Discontinuation of production shall be notified with Mitsubishi Technical Bulletins, etc.
- (2) Product supply (including repair parts) is not available after production is discontinued.

3. Overseas service

Overseas, repairs shall be accepted by Mitsubishi's local overseas FA Center. Note that the repair conditions at each FA Center may differ.

4. Exclusion of loss in opportunity and secondary loss from warranty liability

Regardless of the gratis warranty term, Mitsubishi shall not be liable for compensation to:

- (1) Damages caused by any cause found not to be the responsibility of Mitsubishi.
- (2) Loss in opportunity, lost profits incurred to the user by Failures of Mitsubishi products.
- (3) Special damages and secondary damages whether foreseeable or not, compensation for accidents, and compensation for damages to products other than Mitsubishi products.
- (4) Replacement by the user, maintenance of on-site equipment, start-up test run and other tasks.

5. Changes in product specifications

The specifications given in the catalogs, manuals or technical documents are subject to change without prior notice.

TRADEMARKS

Anywire and AnyWireASLINK are either registered trademarks or trademarks of Anywire Corporation.

The company names, system names and product names mentioned in this manual are either registered trademarks or trademarks of their respective companies.

In some cases, trademark symbols such as [™] or [®] are not specified in this manual.

Anywire Anywire Corporation www.anywire.jp

SH(NA)-081584ENG-C(1904)MEE

MODEL: R-ANYWIRE-U-IN-E

MODEL CODE: 13JX47

MITSUBISHI ELECTRIC CORPORATION

HEAD OFFICE : TOKYO BUILDING, 2-7-3 MARUNOUCHI, CHIYODA-KU, TOKYO 100-8310, JAPAN
NAGOYA WORKS : 1-14, YADA-MINAMI 5-CHOME, HIGASHI-KU, NAGOYA, JAPAN

When exported from Japan, this manual does not require application to the
Ministry of Economy, Trade and Industry for service transaction permission.

Specifications subject to change without notice.